



## ENGINE PROTECTION WIDER PLATE

### PR907B Black

### PR907S Silver

DUCATI Desert X (2022+)

#### NOTICE

Only suitable in combination with tank guard PR901B.

Also mountable in combination with additional guard PR902B.

#### **Content**

**1x Skid plate**

**1x Holder left**

**1x Holder right**

**1x Holder front**

**1x Holder rear left**

**1x Screw kit:**

1 Hexagon screw M12x350 Hexagon

1 screw M12x100

4 Countersunk screw M8x25

5 Countersunk screw M6x20

2 Washer  $\varnothing 12,5$

4 Countersunk washer M8

5 Countersunk washer M6

1 Steel spacer  $\varnothing 30 \times \varnothing 13 \times 32$  black

2 Cover cap M12

#### **Important:**

We recommend having the installation carried out in a professional workshop. During installation, tighten all accessible screws loosely at first to ensure tension-free installation. When tightening the screws, observe the tightening torques.

#### **Preparatory actions**

The original skid plate and the brackets are omitted, the screws of the front and left bracket are reused. Remove the cable clamps on the left-hand holder. If the tank guard is already mounted, remove the allen screw M12x300, this is no longer required.

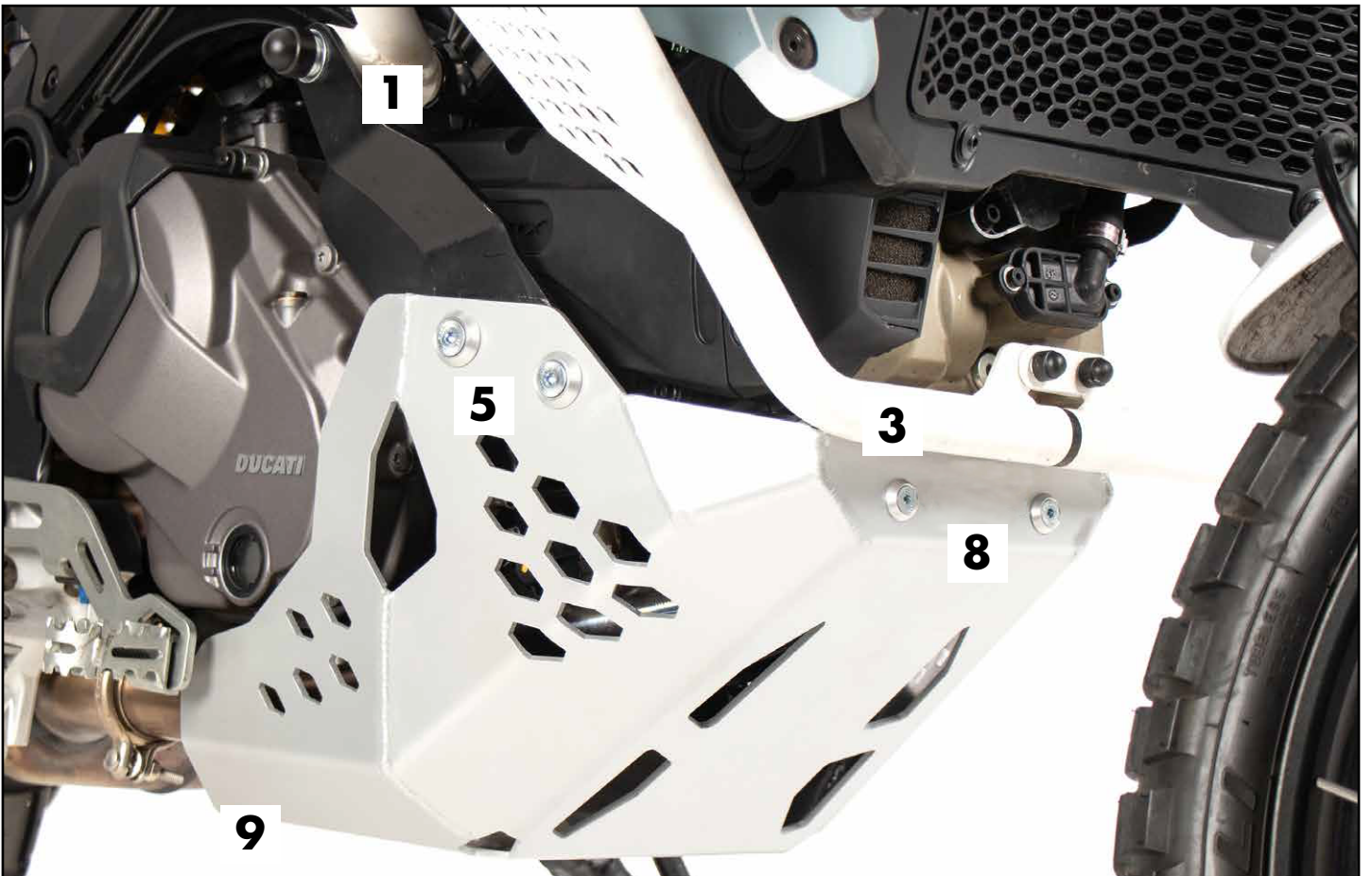
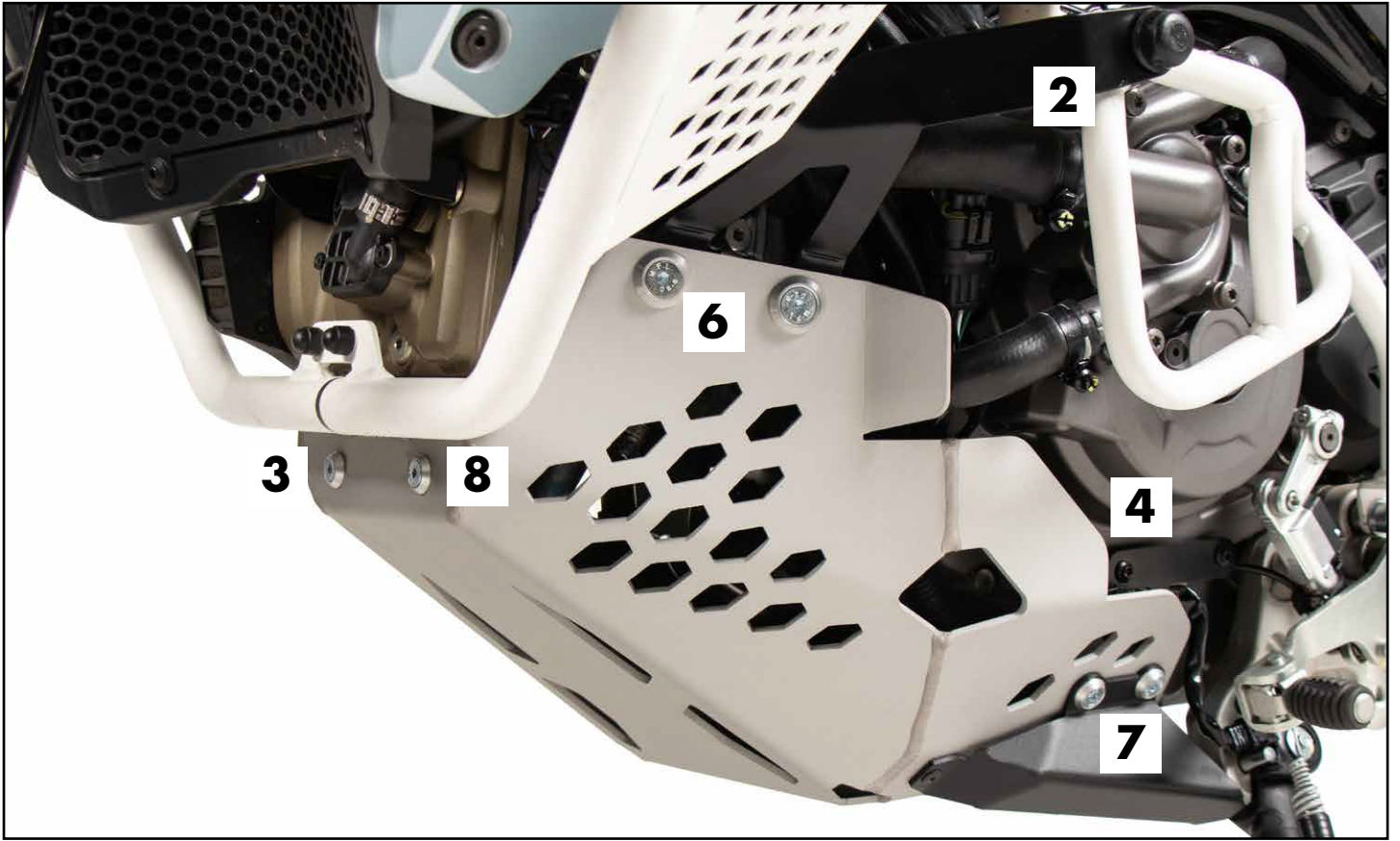

## Installation Instruction

**Fastening of the holder top right:** Use hexagon bolt M12x350 and washer  $\varnothing 12,5$  on the already moun-  
ted tank guard. Fit the cover cap.

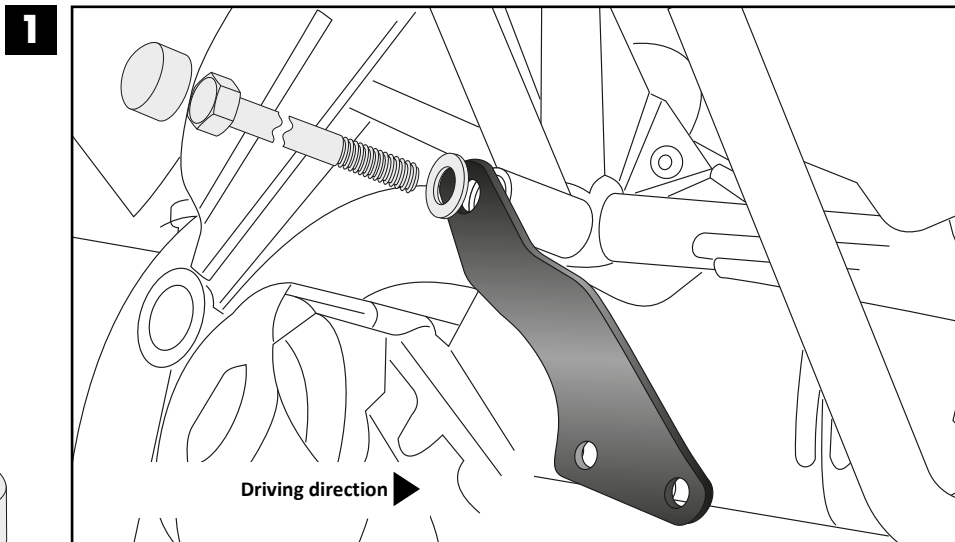
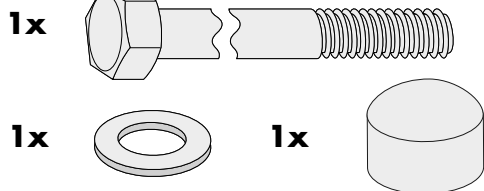

**Fastening of the holder top left:**

Use hexagon bolt M12x100 and washer  $\varnothing 12.5$  on the mounted tank guard. Insert the steel spacer  $\varnothing 30 \times \varnothing 13 \times 32$  between the tank guard and the holder. Fit the cover cap.

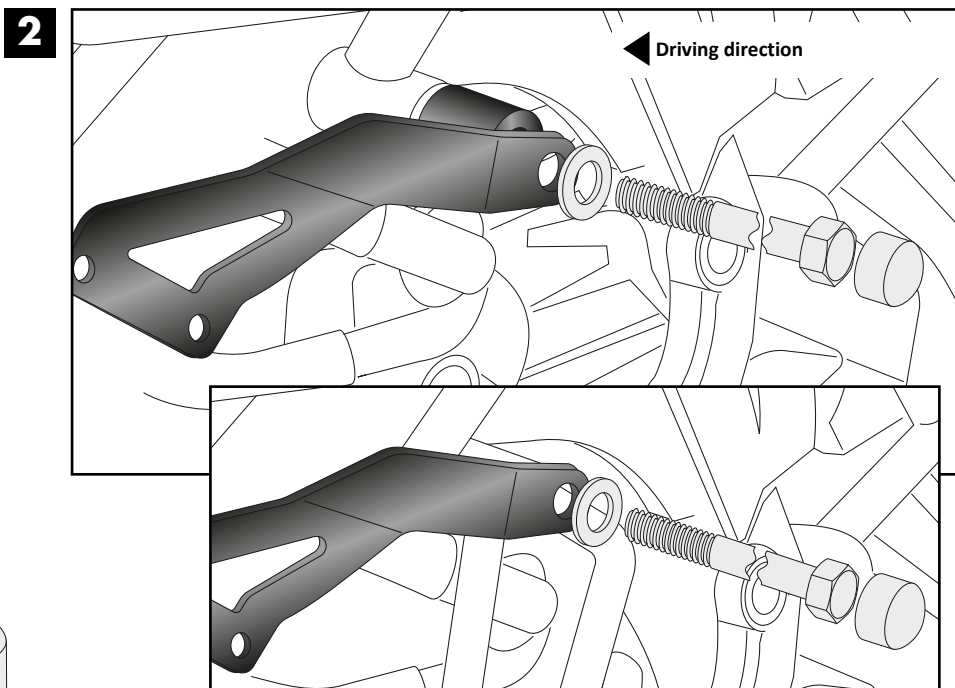
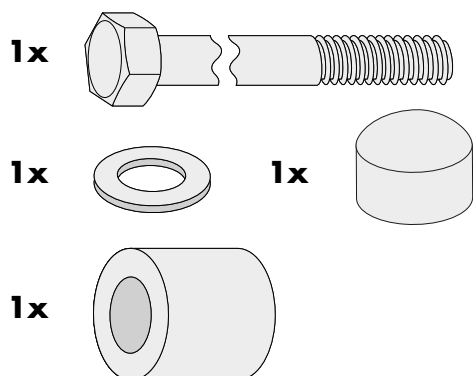

Fastening in combination with additional guard PR902B The steel spacer  $\varnothing 30 \times \varnothing 13 \times 32$  is omitted.

**Fastening of the holder front:**

With the original screws.

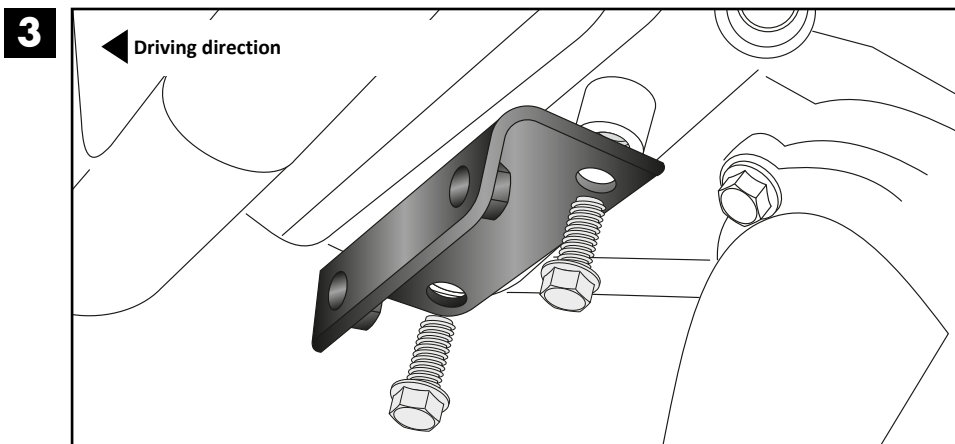

**Fastening of the holder rear left:**

With the original screws.  
Fit the cable clamps to the bracket.

**4**

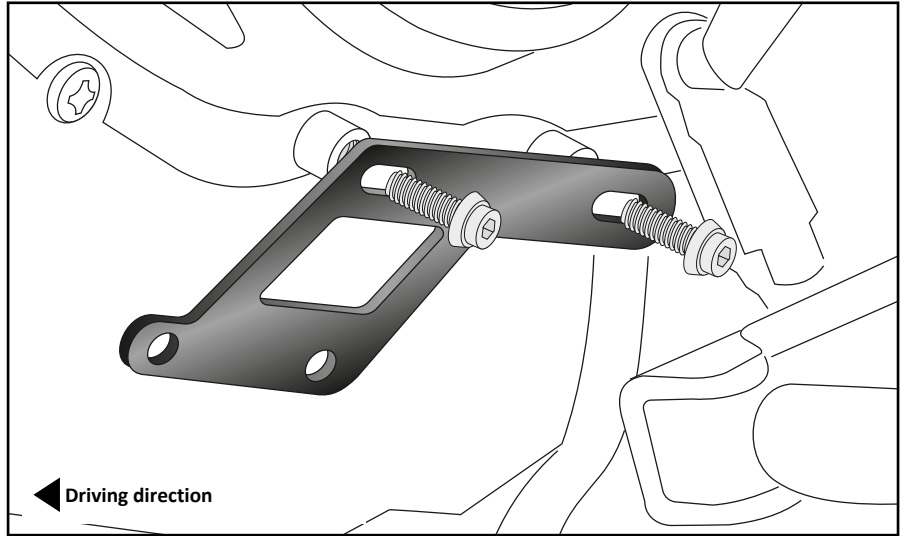

**Fastening of the skid plate middle right:**

On the mounted holder.  
Use countersunk screws M8x25 with  
countersunk washers M8.

**5**

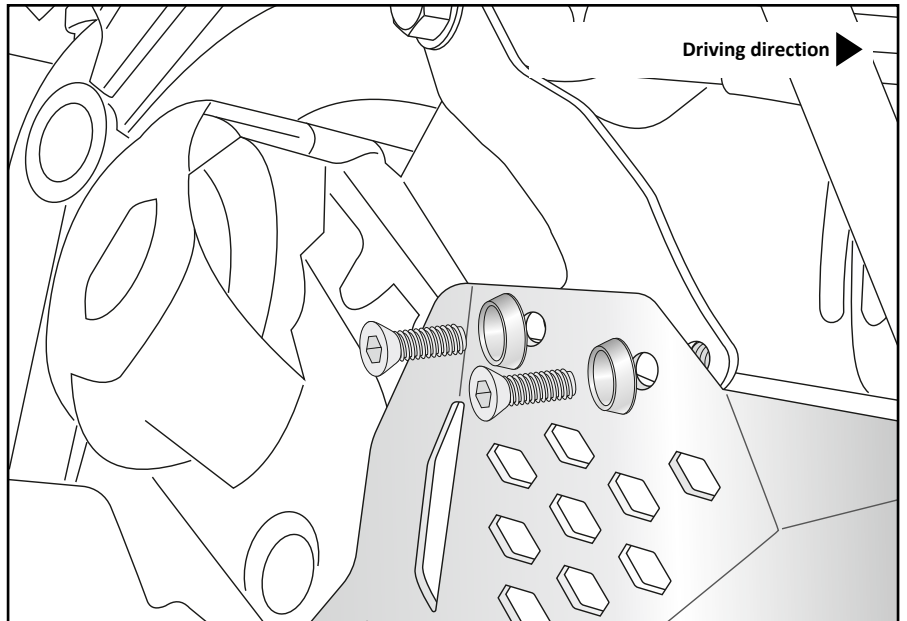

**2x**

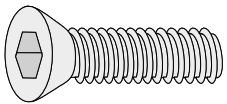

**2x**

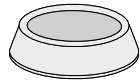

**Fastening of the skid plate middle left:**

On the mounted holder.  
Use countersunk screws M8x25 with  
countersunk washers M8.

**6**

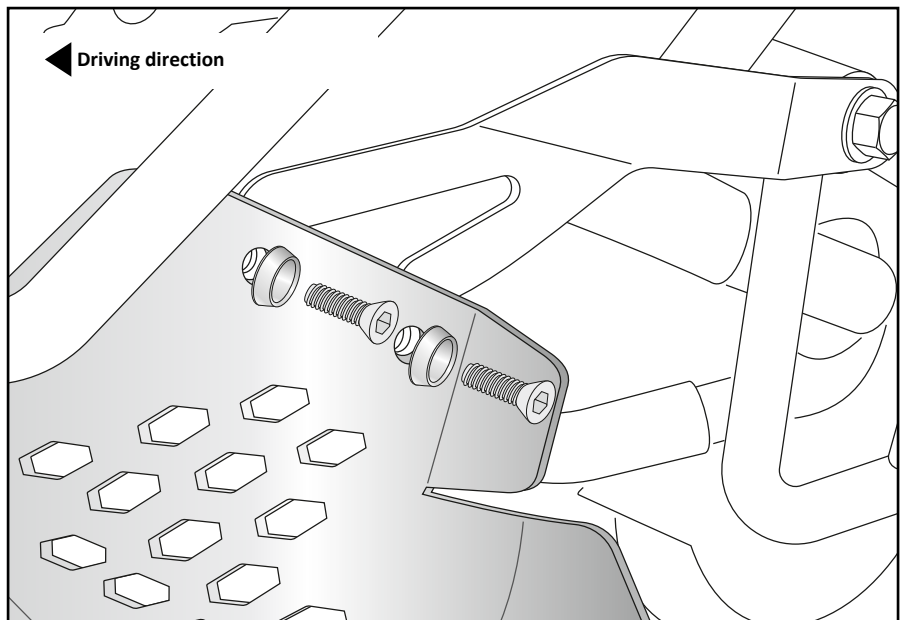

**2x**

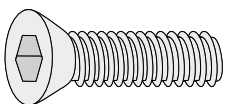

**2x**



**Fastening of the skid plate rear left:**

On the mounted holder.

Use countersunk screws M6x20 with countersunk washers M6.

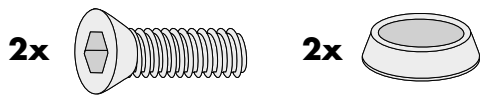

**7**

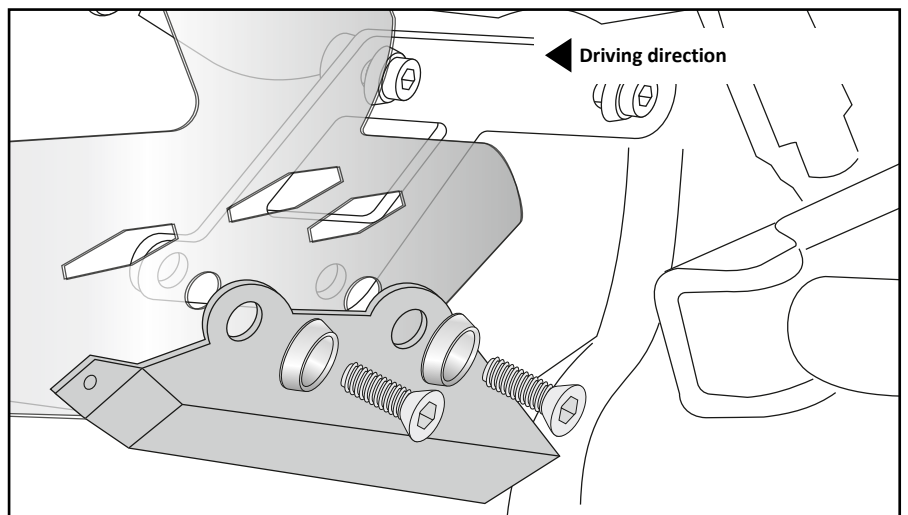

**Fastening of the skid plate front:**

On the mounted holder.

Use countersunk screws M6x20 with countersunk washers M6.

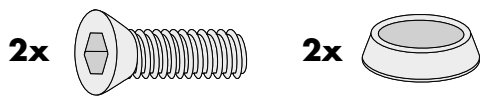

**8**

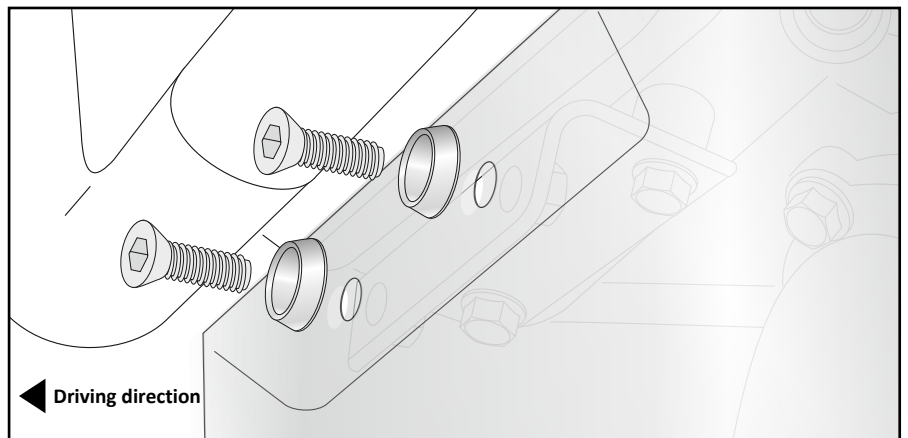

**Fastening of the skid plate rear bottom:**

With countersunk screw M6x20 and countersunk washer M6 on the oil drain plug.

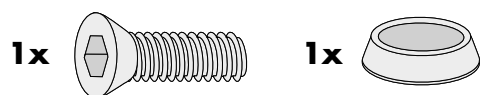

**9**

