

Fitting Instructions for Dual Injector Drop Arm Adapter

SA-0091



* Parts marked are not in the Dual Injector Kit, but are in the adapter kit SA-0091 available FOC from your dealer or from Scottoil direct

The adapter kit combined with the Dual Injector kit will allow fitting to certain models.

Please check you have the parts shown * in the diagram on the left.

Fit the Dual injector body to the post on the mounting arm.

Hold the mounting block with bolt on the top of the swingarm and insert spacers on the M6x70mm alloy bolt to achieve alignment with the chain using lock washers between any two plastic surfaces.

Once satisfied that alignment is central, the M6 bolt can be trimmed if necessary, then fit the pozi screw and plastic washer to fix the Dual Injector body to the arm then tighten the M6 alloy bolt fully.

Note: the pozi screw will self tap a thread into the post on the mounting arm. If unscrewing and rescrewing this part take care not to cross or strip the thread.

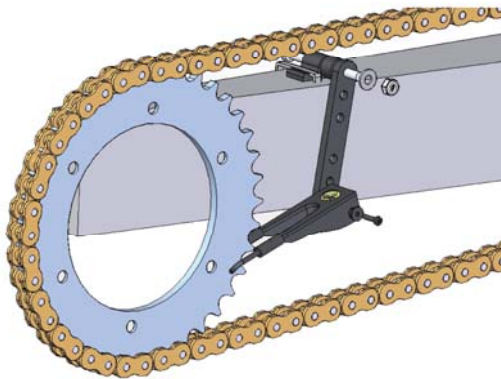

The injectors should lie in line with the chain, but not resting on it. Remember to allow for play in the chain. The injector tips should rest at about the '7 o'clock' position on the sprocket. Nibs should rest against sprocket face angled slightly inwards, but pointing downwards.

HINT: The nibs can be trimmed to give maximum clearance on sprocket.

Read general Dual Injector instructions in conjunction with this guide.

If you have any further comments or queries, and are unable to resolve them using our website, please do not hesitate to call technical on 0141 955 1100 or email technical@scottoiler.com for assistance. Thank you.
Scottoil Limited, 2 Riverside, Milngavie, Glasgow, G62 6PL Tel 0141 955 1100 Fax. 0141 956 5896