

PL539 - KL539

PORTAVALIGIE LATERALE SPECIFICO - SPECIFIC TUBULAR SIDE-CASE HOLDER
 PORTE-VAISES LAT RAUX SP CIFIQUE - SPEZIFISCHES STAHLROHR-SEITENTRÄGER
 PORTA MALETAS LATERALES ESPECIFICO

SUZUKI GSF650/1250cc '07 BANDIT

ISTRUZIONI DI MONTAGGIO - MOUNTING INSTRUCTIONS
 INSTRUCCIONS DE MONTAGE - BAUANLEITUNG - INSTRUCCIONES DE MONTAJE

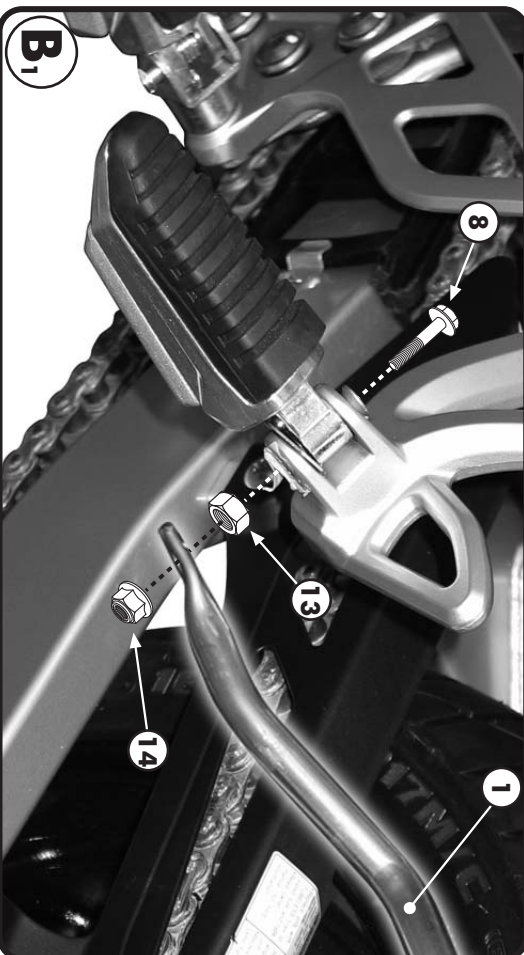
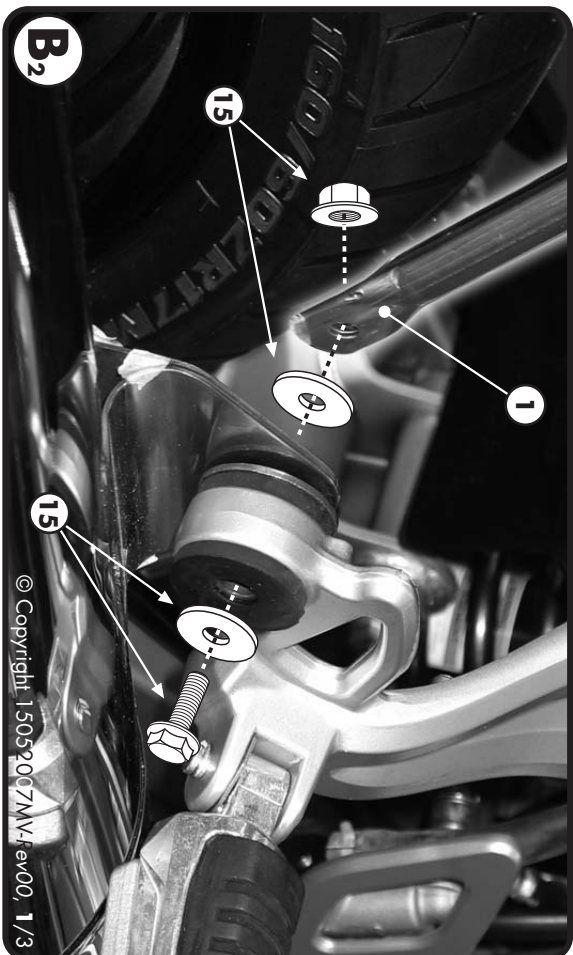
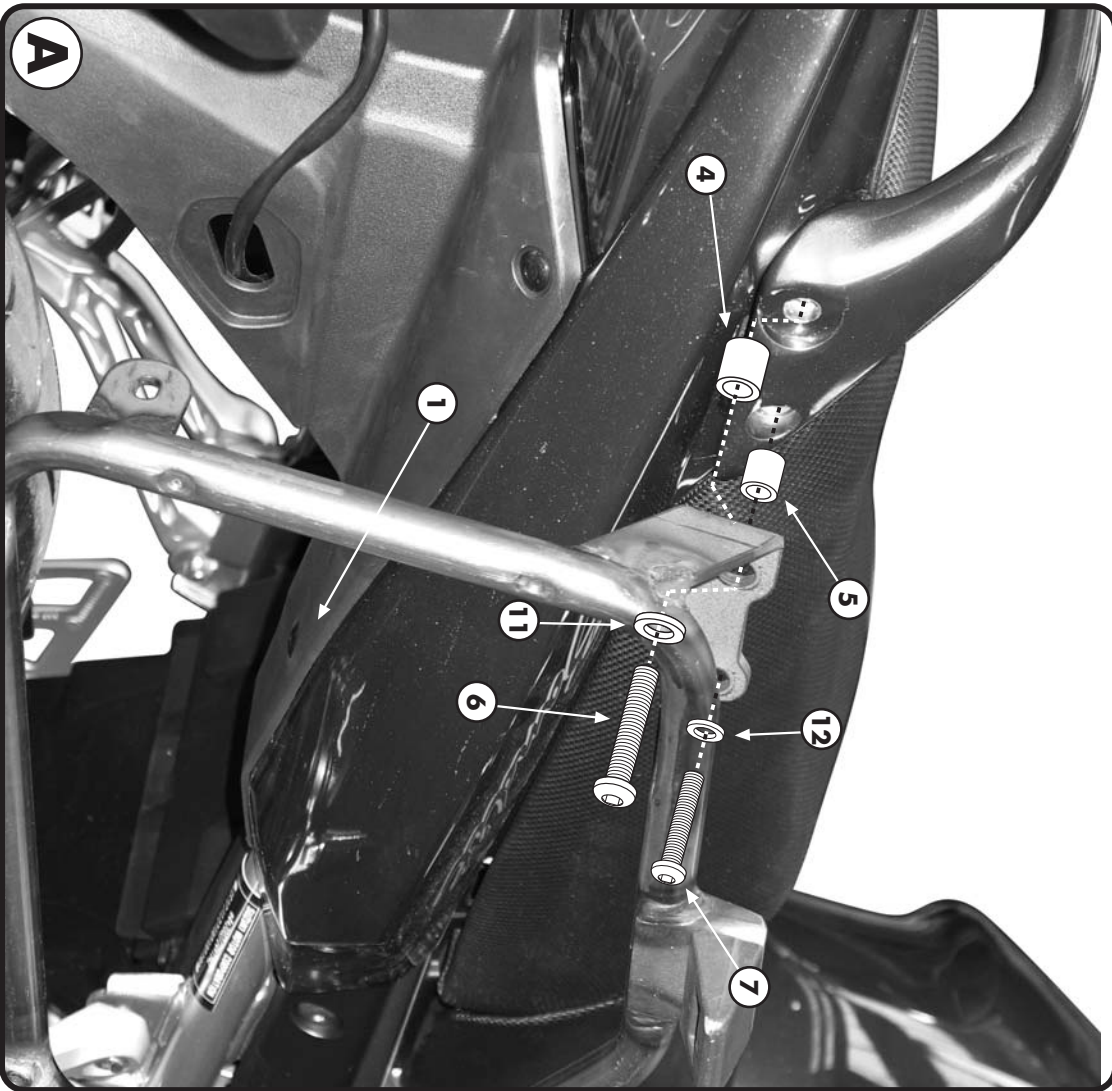

1

SUPPORTO
 SUPPORT
 SUPPORT
 SUPPORT
 SÖLÖRTE
Q.TY n.2(dx-sx)

2

PONTE POSTERIORE
 REAR BRIDGE
 POINT POSTERIEURE
 WEHRHINDENGERICH
 PUENTE TRASERO
Q.TY n.1

3

SUPPORTO FRECCIA
 BLINKER SUPPORT
 SUPPORT CLIGNOYANT
 BLINKER HALTER
 SOPORTE INTERMITENTE
Q.TY n.1

4

DISTANZIALE f12x21mm
 Spacers f12x21mm
 ENTRETOISE
 DISTANZSTÜCK
 DISTANCIADOR
Q.TY n.2

5

DISTANZIALE f14x20mm
 Spacers f14x20mm
 ENTRETOISE
 DISTANZSTÜCK
 DISTANCIADOR
Q.TY n.2

6

VITE T8E1 M8x80mm
 SCREW M8x80mm
 VIS M8x80mm
 SCHRAUBE M8x80mm
 TORNILLO M8x80mm
Q.TY n.2

A

B2

B1

PL539 - KL539

PORTALUIGIE LATERALE SPECIFICO - SPECIFIC TUBULAR SIDE-CASE HOLDER
PORTE-VALEES LAT RAUX SP CIRQUE - SPECIFISCHES STAHRORH-SEITENTRÄGER
PORTA MALETAS LATERALES ESPECIFICO

SUZUKI GSF650/1250cc '07

BANDIT

ISTRUZIONI DI MONTAGGIO - MOUNTING INSTRUCTIONS
INSTRUCIONS DE MONTAGE - BAUANLEITUNG - INSTRUCCIONES DE MONTAJE



10

DADO A.B. M6
BOLT M6
ECROU M6
MUTTER M6
TUERCA M6

Q.TY n.2



11

RONDELLA 18x14mm
WASHER 18x14mm
RONDELLE 18x14mm
SCHEIBE 18x14mm
ACANDELA 18x14mm

Q.TY n.2



12

RONDELLA 16mm
WASHER 16mm
RONDELLE 16mm
SCHEIBE 16mm
ACANDELA 16mm

Q.TY n.2



13

DADO M8
BOLT M8
ECROU M8
MUTTER M8
TUERCA M8

Q.TY n.1



14

DADO A.B. M8
BOLT M8
ECROU M8
MUTTER M8
TUERCA M8

Q.TY n.1

15

COMPONENTI ORIGINALI
ORIGINAL PARTS
ORIGINAL BAUTEILE
COMPONENTES ORIGINALES

Q.TY n.-

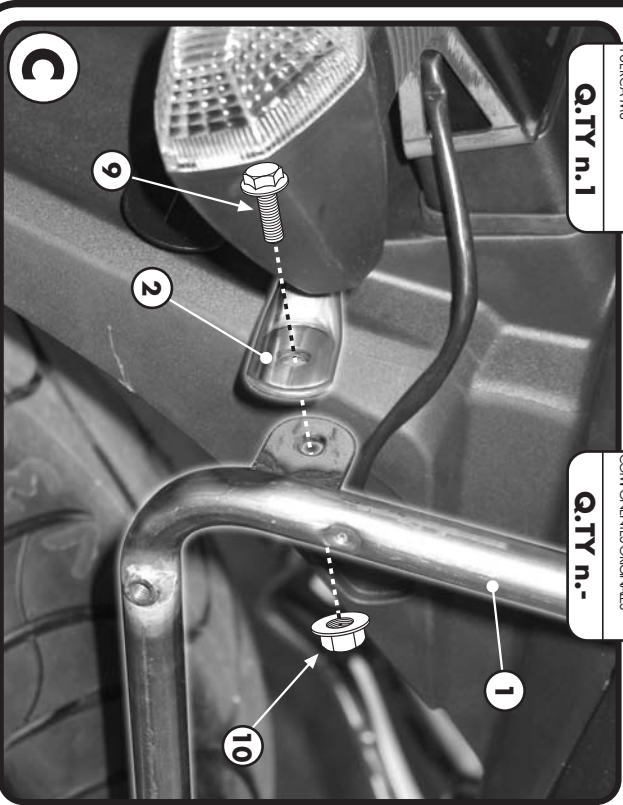

C

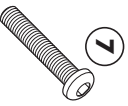

7

VITE TEF M6x70mm
SCREW M6x70mm
VIS M6x70mm
SCHRAUBE M6x70mm
TORNILLO M6x70mm

Q.TY n.2

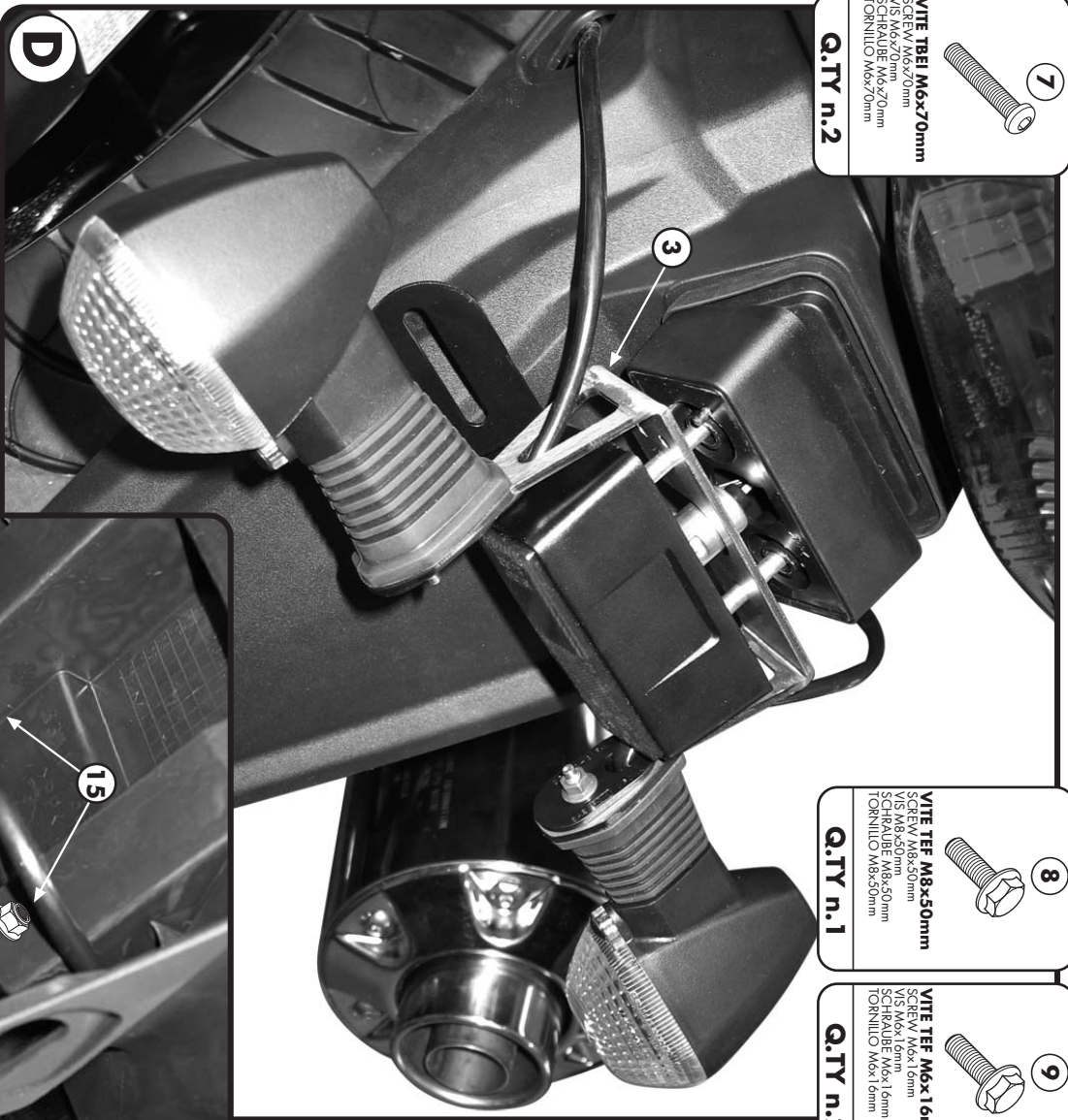

D

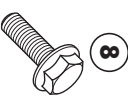

8

VITE TEF M8x50mm
SCREW M8x50mm
VIS M8x50mm
SCHRAUBE M8x50mm
TORNILLO M8x50mm

Q.TY n.1

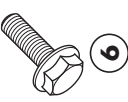

9

VITE TEF M6x16mm
SCREW M6x16mm
VIS M6x16mm
SCHRAUBE M6x16mm
TORNILLO M6x16mm

Q.TY n.2

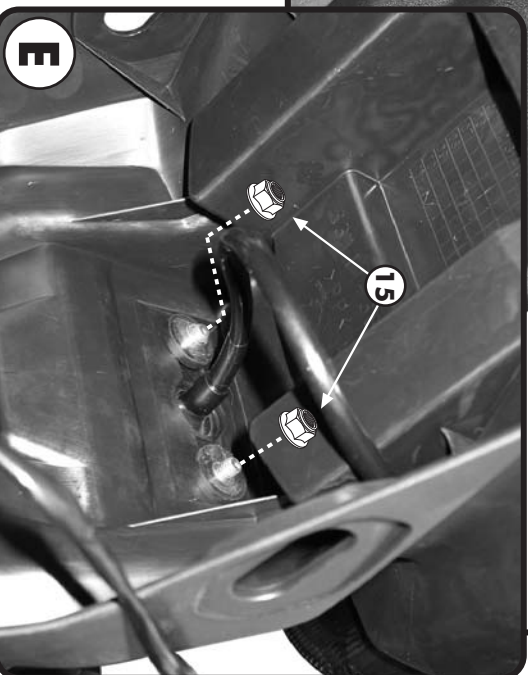

E

PORTAVALLIGIE LATERALE SPECIFICO - SPECIFIC TUBULAR SIDE-CASE HOLDER
 PORTE-VALISES LAT RAUX SP CIFIQUE - SPEZIFISCHES STAHLROHR-SEITENTRÄGER
 PORTA MALETTAS LATERALES ESPECIFICO

SUZUKI GSF650/1250cc '07
BANDIT

ISTRUZIONI DI MONTAGGIO - MOUNTING INSTRUCTIONS
 INSTRUCCIONES DE MONTAJE - BAUANLEITUNG - INSTRUCCIONES DE MONTAJE

I ISTRUZIONI DI MONTAGGIO

1. MONTARE IL PORTAVALLIGIE LATERALE COME INDICATO IN FOTOGRAFIA A, B E C. NEL CASO IN CUI SI MONTI IL PORTAVALLIGIE LATERALE IN PRESENZA DEL MONORACK (PORTAVALLIGIA CENTRALE) NON BISOGNA UTILIZZARE I PARTICOGLARI 4 E 5. INDICATI IN FOTOGRAFIA A.
2. SMONTARE LE FRECCIE DALLA LORO POSIZIONE D'ORIGINE E MONTARLE AL SUPPORTO N°3.
3. MONTARE IL SUPPORTO FRECCIE N°3 SEGUENDO COME ESEMPIO IL MONTAGGIO COMPOSTO IN FOTOGRAFIA D, PER IL FISSAGGIO FAR RIFERIMENTO ANCHE ALLA FOTOGRAFIA E.
4. ULTIMARE IL MONTAGGIO CONTROLLANDO CHE TUTTE LE VITI SIANO SERRATE BENE.

GB MOUNTING INSTRUCTIONS

1. MOUNT THE SIDE-CASE HOLDER AS INDICATED IN PICTURES A, B AND C. IF YOU MOUNT THE SIDE-CASE WITH THE MONORACK (TOPCASE CARRIER) YOU DO NOT NEED TO USE THE PARTS N° 4 AND 5 INDICATED IN PICTURE A.
2. REMOVE THE INDICATORS FROM THEIR ORIGINAL POSITION AND MOUNT THEM TO THE SUPPORT N° 3.
3. MOUNT THE INDICATOR SUPPORT N° 3 AS SHOWN IN PICTURE D, AND FOR FIXING IT MAKE REFERENCE TO PICTURE E.
4. LASTLY CHECK THAT ALL SCREWS HAVE BEEN TIGHTENED.

F INSTRUCTIONS DE MONTAGE

1. MONTER LES PORTE-VALISES LATERAUX COMME INDIQUE EN PHOTOS A, B ET C. DANS LE CAS OU ON MONTE LES PORTE-VALISES LATERAUX AVEC LE MONORACK (PORTE-VALISE CENTRAL) ON NE DOIT PAS UTILISER LES PIECES 4 ET 5 INDIQUEES EN PHOTO A.
2. DEMONTER LES CLIGNOTANTS DE LEUR POSITION D'ORIGINE ET LES MONTER A NOUVEAU AU SUPPORT N°3.
3. MONTER LE SUPPORT-CLIGNOTANTS N°3 EN SUIVANT L'EXEMPLE DU MONTAGE EN PHOTO D, POUR LA FIXATION SE REFERER AUSSI A LA PHOTO E.
4. TERMINER LE MONTAGE EN CONTROLANT LE BON SERRAGE DE TOUTES LES VIS.

D BAUANLEITUNG

1. MONTIEREN SIE DEN SEITENKOFFERTRÄGER WIE IN DEN BILDER A, B UND C BESCHRIEBEN. FALLS DER SEITENKOFFERTRÄGER MIT DEM MONORACK (TOPCASE TRÄGER) MONTIERT WIRD, VERWENDEN SIE NICHT DIE TEILE NR. 4 UND 5 VOM BILD A.
2. ENTFERNEN SIE DIE BLINKER VON DER ORIGINALSTELLE UND MONTIEREN SIE DIE HALTERUNG NR. 3.
3. MONTIEREN SIE DIE BLINKERHALTERUNG NR. 3 WIE IN DER ABGEBILDETEN MONTAGE VOM BILD D, FÜR DIE BEFESTIGUNG NEHMEN SIE AUCH AUF BILD E BEZUG.
4. ZULETZT ÜBERPRÜFEN SIE, DASS ALLE SCHRAUBEN FESTGEZOGEN WURDEN

ES

INSTRUCCIONES DE MONTAJE

1. MONTAR EL PORTAMALETAS LATERAL SEGÚN MUESTRAN LAS FOTOGRAFÍAS A, B Y C. EN EL CASO DE MONTAR EL PORTAMALETAS LATERAL CON EL MONORACK (PORTAMALETAS CENTRAL) NO ES NECESARIO UTILIZAR LOS ESPECÍFICOS 4 Y 5 INDICADOS EN LA FOTOGRAFÍA A.
2. DESMONTAR LOS INDICADORES DE LA POSICIÓN ORIGINAL Y MONTARLOS AL SOPORTE N° 3.
3. MONTAR EL SOPORTE PARA LOS INDICADORES N° 3 SEGÚN LAS INDICACIONES DE MONTAJE EN LA FOTOGRAFÍA D. PARA LA FIJACIÓN REMITIRSE A LA FOTOGRAFÍA E.
4. TERMINAR EL MONTAJE CONTROLANDO QUE TODOS LOS TORNILLOS ESTEN BIEN AJUSTADOS.